

8AS

8FT APEX SUMMERHOUSE INSTRUCTIONS

SHEPAST



Base Sizes

	<u>Width (mm)</u>	<u>Length (mm)</u>
<u>8x6</u>	2390mm	1883mm
<u>8x8</u>		2478mm
<u>8x10</u>		3078mm
<u>8x12</u>		3673mm
<u>8x14</u>		4273mm
<u>8x16</u>		4868mm

AS342

AS342



Introduction

Warranty -

Your Shedfast shed is guaranteed for two years against faulty manufacture as long as you treat it within two weeks of assembly with our recommended treatment. The guarantee would supply replacement planks or parts for any defective items (ie rarely a full panel) for self installation. Wind damage, non-domestic use, accidental or deliberate damage and Labour are all excluded from the guarantee.

Care and Maintenance-

Your Shedfast shed is made from good quality Scandinavian timber and should give you years of reliable use. However it is important to be aware of the natural properties of wood and accept these changes as they crop up on your shed. This kind of timber is affected by humidity which expands the timber as it gets wetter and shrinks it as it dries out. For this reason it is highly beneficial to treat your shed immediately when it is assembled with a good quality wood treatment. We offer the Shedfast original larch colour in a 2.5l can and you should use this if you want to keep a similar colour to the original. Alternatively, if you want to paint your new building in a coloured finish, then we offer the Protek Royal exterior which is a superb quality coating.

Although your shed comes with a factory applied premium protector treatment, the benefits of hand painting the shed immediately with one of our recommended treatments are so profound that we will only activate the 2 year warranty if your shed is coated with one of our recommended treatments within 2 weeks of assembly.

Please be aware that timber is a natural product and can split, warp, cup, expand and contract, leech sap, shed knots, shake and twist. These matters can be mitigated by applying a treatment immediately when you get your shed and by filling shakes, splits and knot holes as they crop up as a part of your ongoing maintenance. Check your shed annually and fill any defects that have developed.

Safety information-

- Glass and timber can potentially cause injury. Please ensure you wear protective goggles, gloves, headgear and suitable footwear when assembling the building.
- Please remember that glass is fragile and should be handled with extreme care. Always clear up and dispose of any breakages immediately.
- Do not assemble the shed in high winds.
- For safety reasons and ease of assembly when self-assembling, we recommend that this shed is assembled by two people.
- Please clear all lying snow from the shed roof as it can cause the roof to buckle or collapse.
- Please do not stand directly or put your whole body weight on the roof.

Site preparation-

- When selecting a site for your shed, it is vital that you choose as flat and level an area as possible.
- A concrete or slabbed base will provide the most solid foundation for your shed. It is important the base is level.
- Avoid placing your shed under trees or in other vulnerable locations if possible.
- To minimise the risk of wind damage, try to select as sheltered a site as possible, e.g. beside a hedgerow or garden fence.

Tools required-

- Drill
- Spirit Level
- Knife
- Ladders
- Hammer
- Screwdriver
- Tape Measure

Pre Assembly

- Before you start, check you have all the correct components required for the build. See the tables on the back pages to check this.
- Remove any of the transit blocks, but be careful when laying the panels down to not snap any of the over-hanging cladding.

Doors-

Always use the turn buttons to help keep the door aligned in its frame. Otherwise it can warp over time. Regular use of the turn buttons keeps the door 'trained'. Please ensure that your door is securely fastened in windy conditions to prevent damage to the hinges or door posts.

Felt-

Your shedfast building comes with a good quality polyester backed felt which is harder to rip than regular shed felt. Keep an eye on your felt as a part of your ongoing maintenance and repair or replace it promptly if it deteriorates (for example after a storm) before water has chance to get in and damage the shed.

Base Sizes

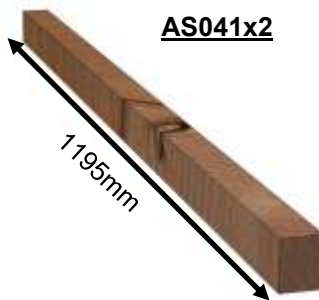
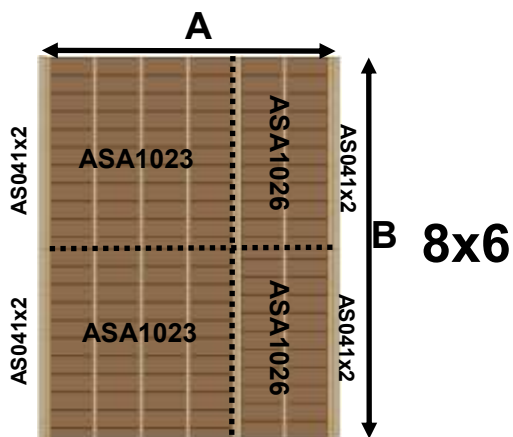

Panels	Size	Quantity
ASA1023	1195x1195	2
ASA1026	1195x600	2
AS041X2	44x56x1195	4

Length (A)	Width (B)
1878mm	2390mm

NOTE: All floors are shown from underneath

NOTE: The shed overhands the floor so adds approx. 30mm

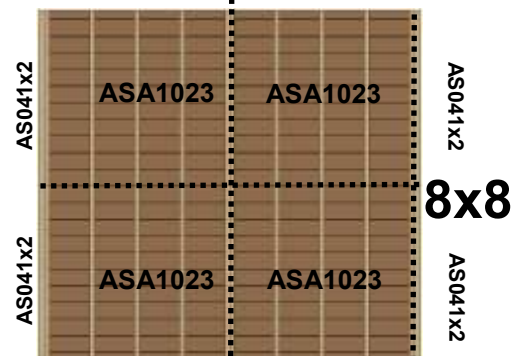

Panels	Size	Quantity
ASA1023	1195x1195	4
AS041X2	44x56x1195	4

Length (A)	Width (B)
2078mm	2390mm

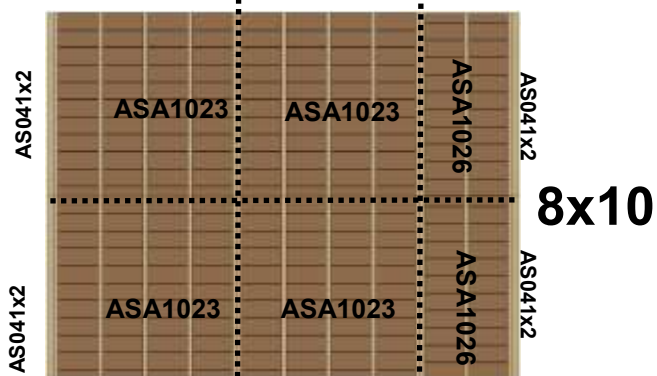

Panels	Size	Quantity
ASA1023	1195x1195	4
ASA1026	1195x600	2
AS041X2	44x56x1195	4

Length (A)	Width (B)
2478mm	2390mm

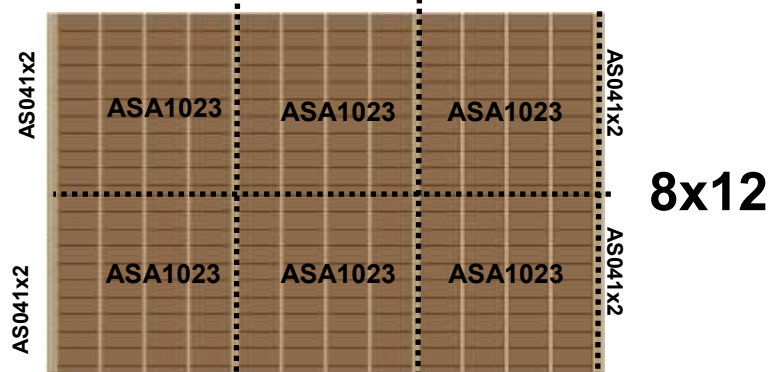

Panels	Size	Quantity
ASA1023	1195x1195	6
AS041X2	44x56x1195	4

Length (A)	Width (B)
3668mm	2390mm

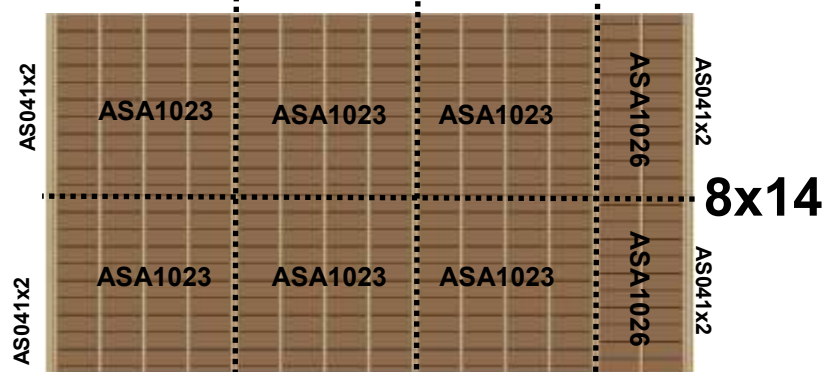

Panels	Size	Quantity
ASA1023	1195x1195	6
ASA1026	1195x600	2
AS041X2	44x56x1195	4

Length (A)	Width (B)
4224	2390mm

Shed Base System (Optional)

The base system is made up of sections that mirror the size of the floor panels . Finally, at each end you need to add an extra batten (AS106) to make the length up.

<u>SHED SIZE</u>	<u>AS103 (300mm)</u>	<u>AS104 (512mm)</u>	<u>AS105 (1107mm)</u>	<u>AS106 (1196mm)</u>	<u>AS107 (1490mm)</u>	<u>AS108 (1790mm)</u>	<u>80mm Screws</u>
<u>8x6</u>	9	6	6	12	0	0	110
<u>8x8</u>	9	0	12	12	0	0	110
<u>8x10</u>	12	6	12	16	0	0	156
<u>8x12</u>	12	0	18	16	0	0	156
<u>8x14</u>	15	6	18	8	0	0	202

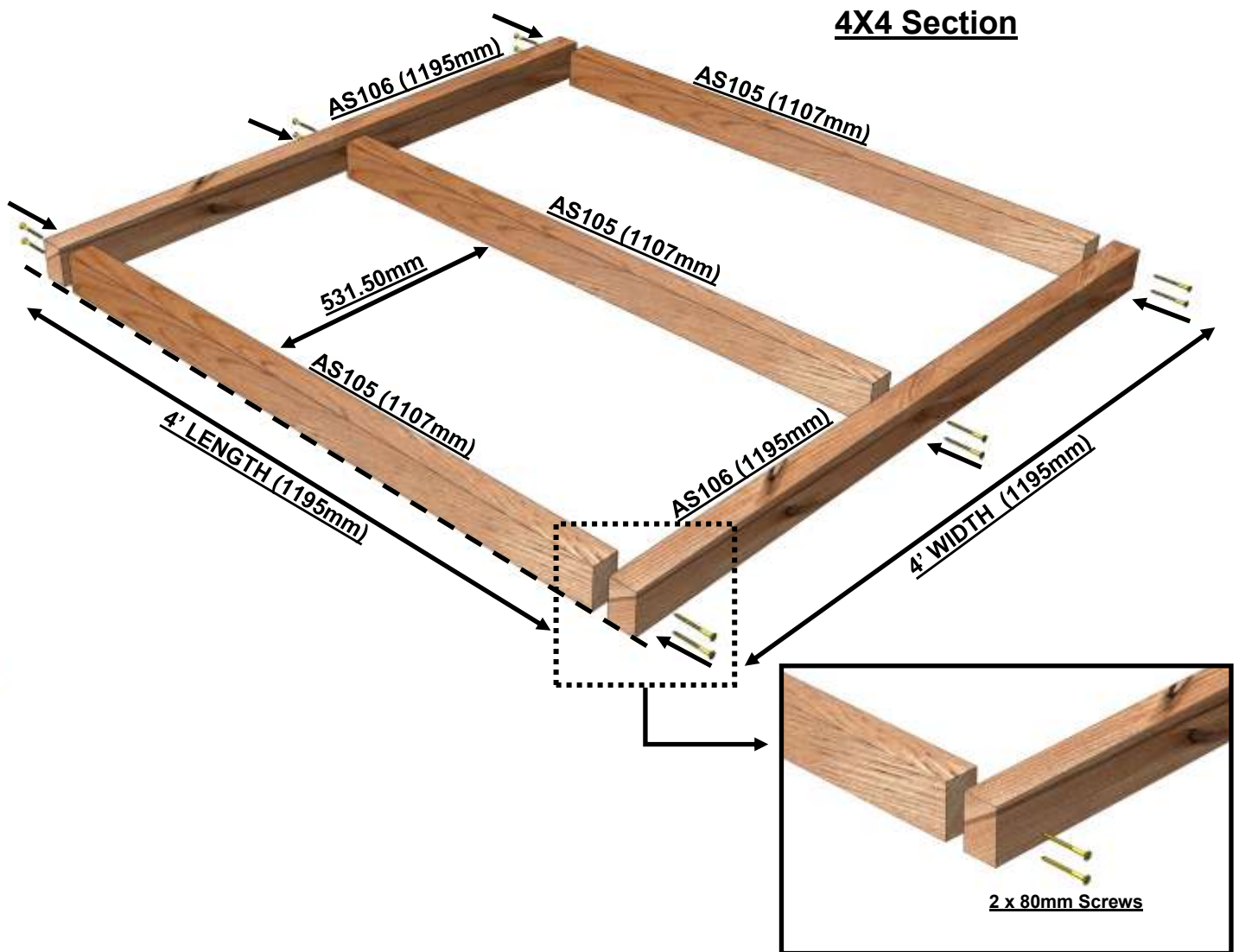

4x2 Section

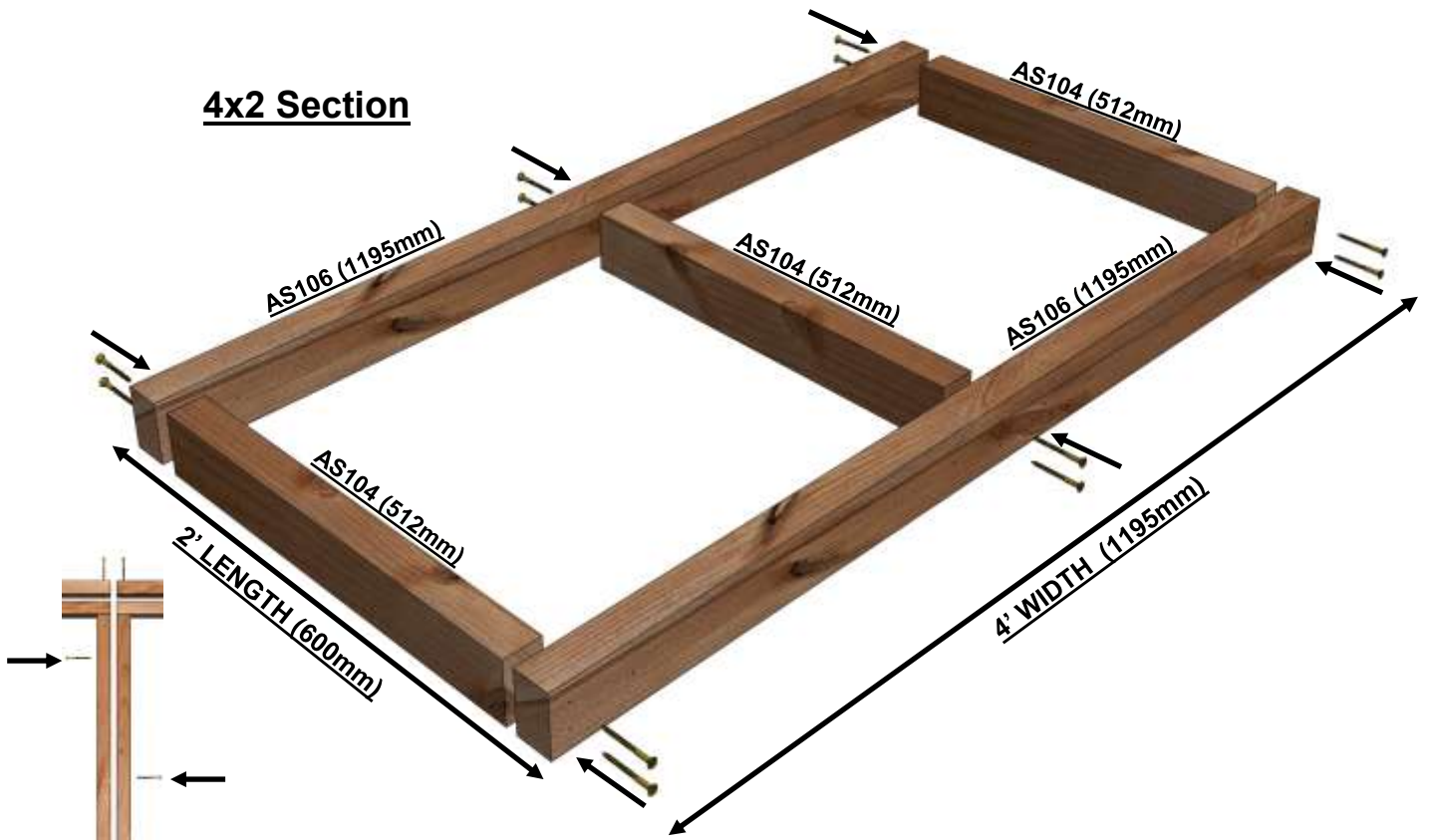

8x6 Example

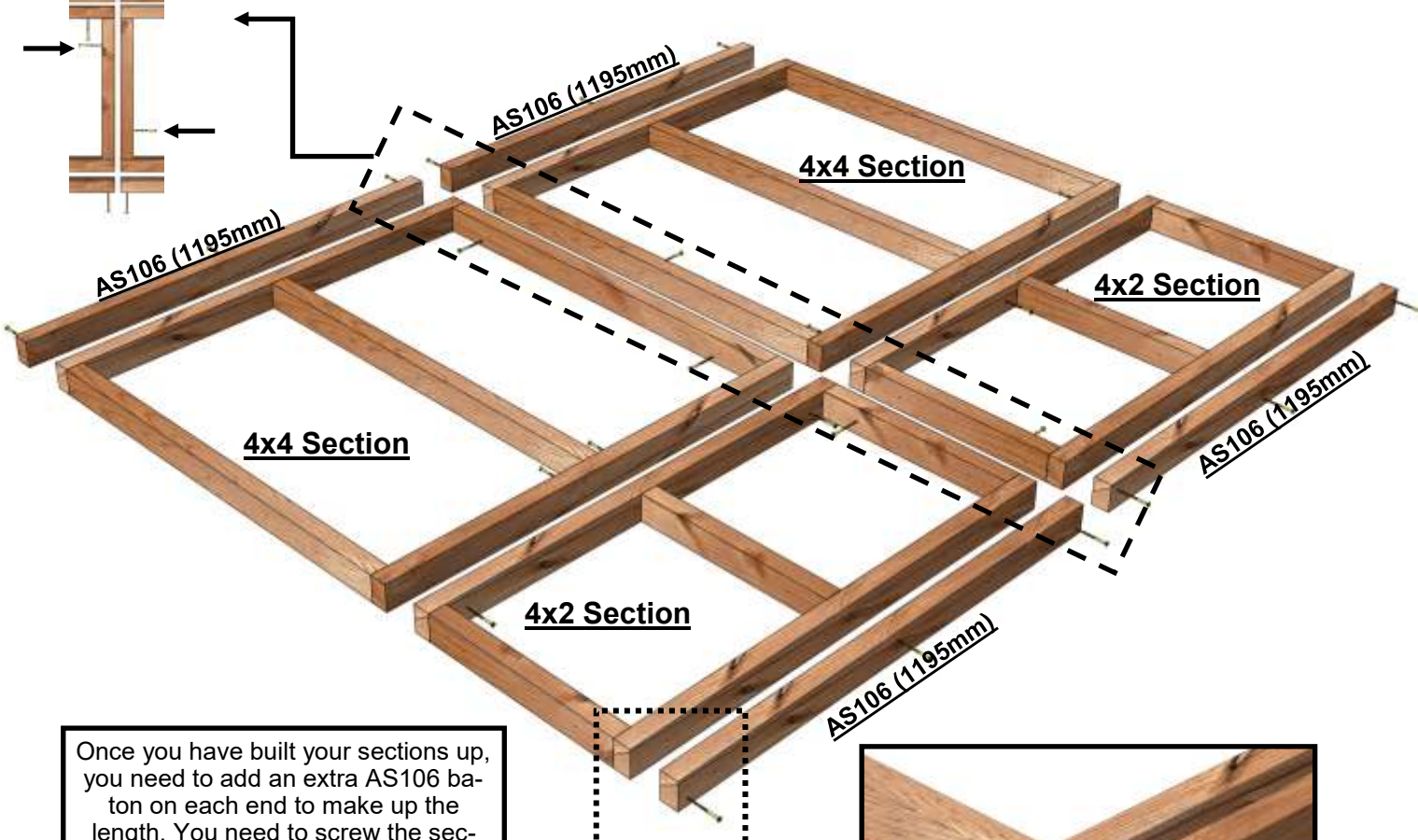

Once you have built your sections up, you need to add an extra AS106 baton on each end to make up the length. You need to screw the sections together using 80mm screws.

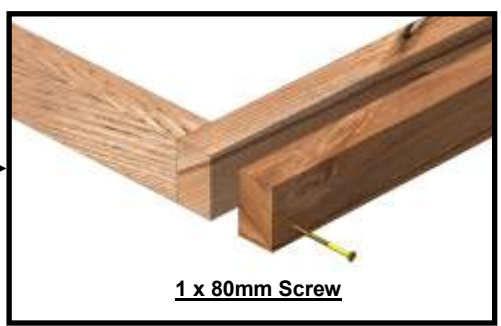

8x8 Example

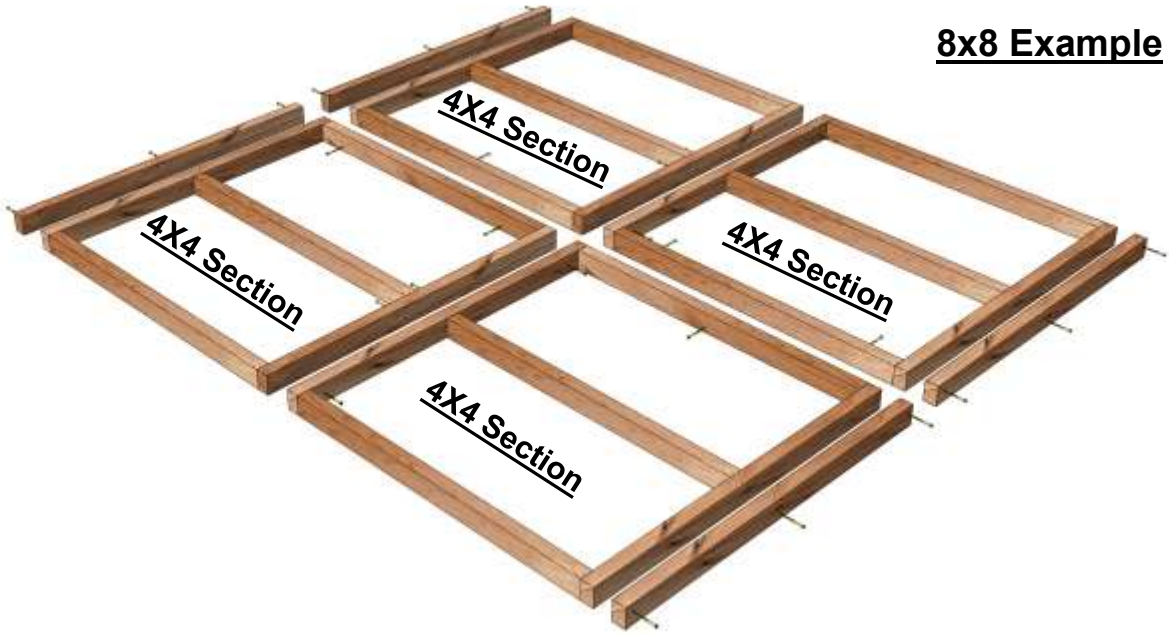

8x10 Example

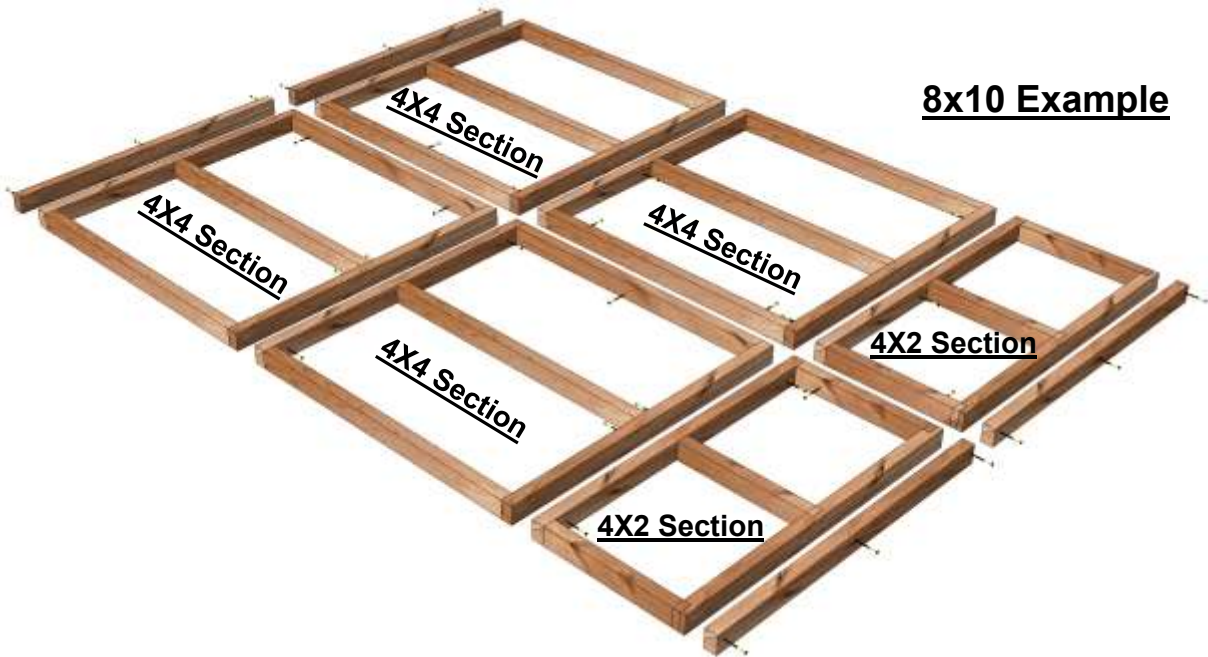

8x12 Example



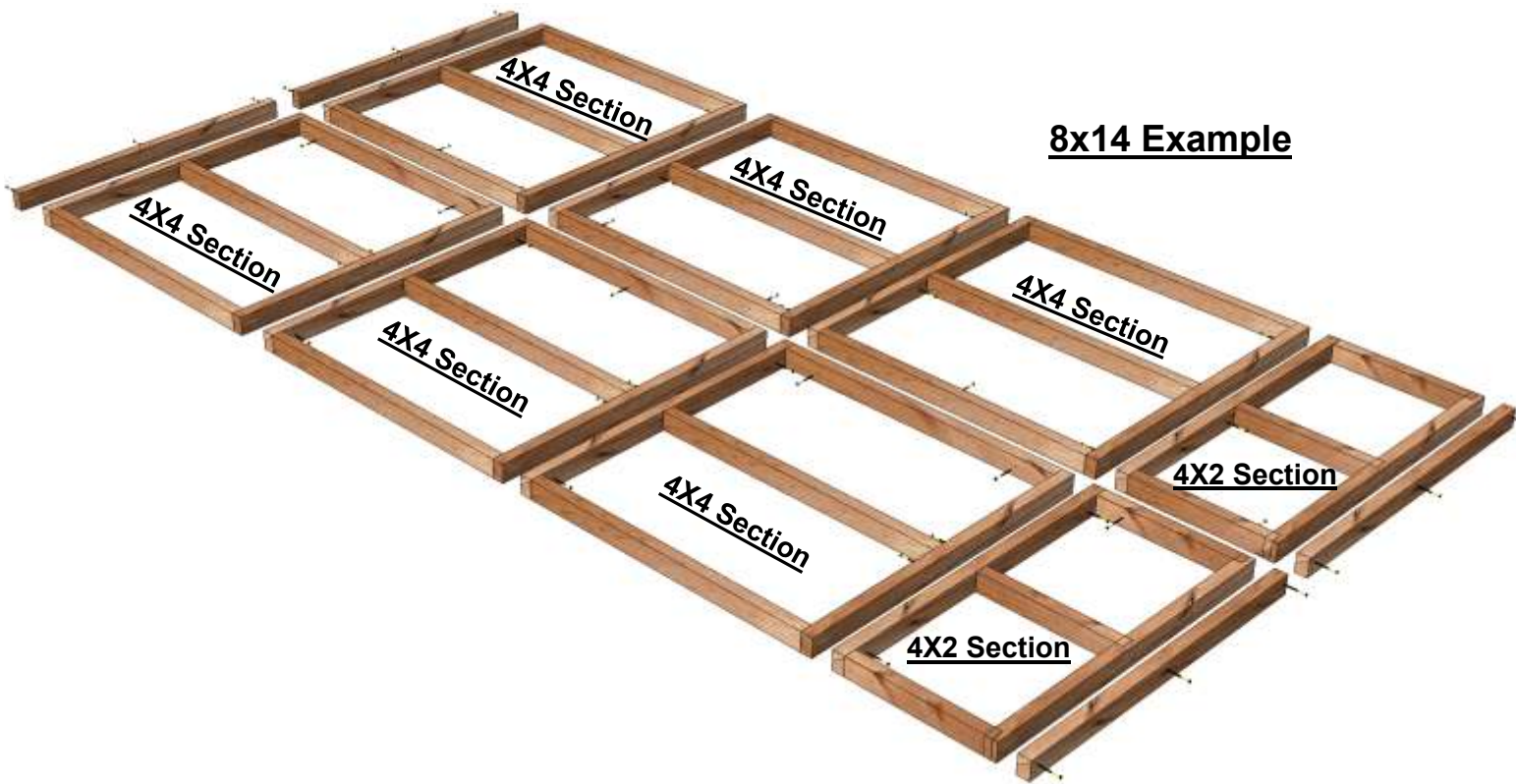

8x14 Example

You will received **AS103 (300mm)** legs with your base. These are to help you level your base before you put the floor on top. You can either put the legs on vertically if you have a big gap to level and saw off the top, let the legs sit into concrete holes in the base below or lie the legs horizontally if you only have a small gap to level. Use a spirit level to ensure the level of the base. You can spread these around the corners of the base to get the best level possible.

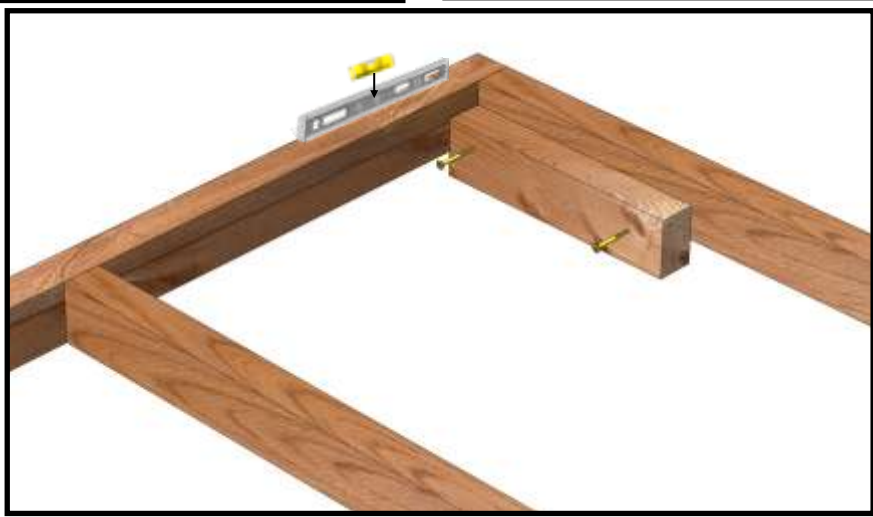
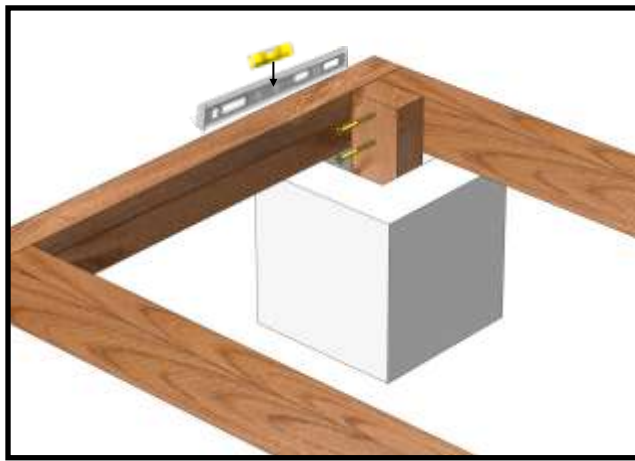
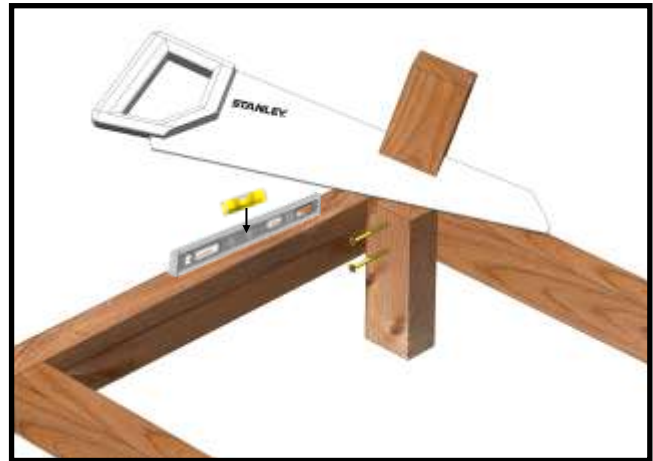

Floor Assembly

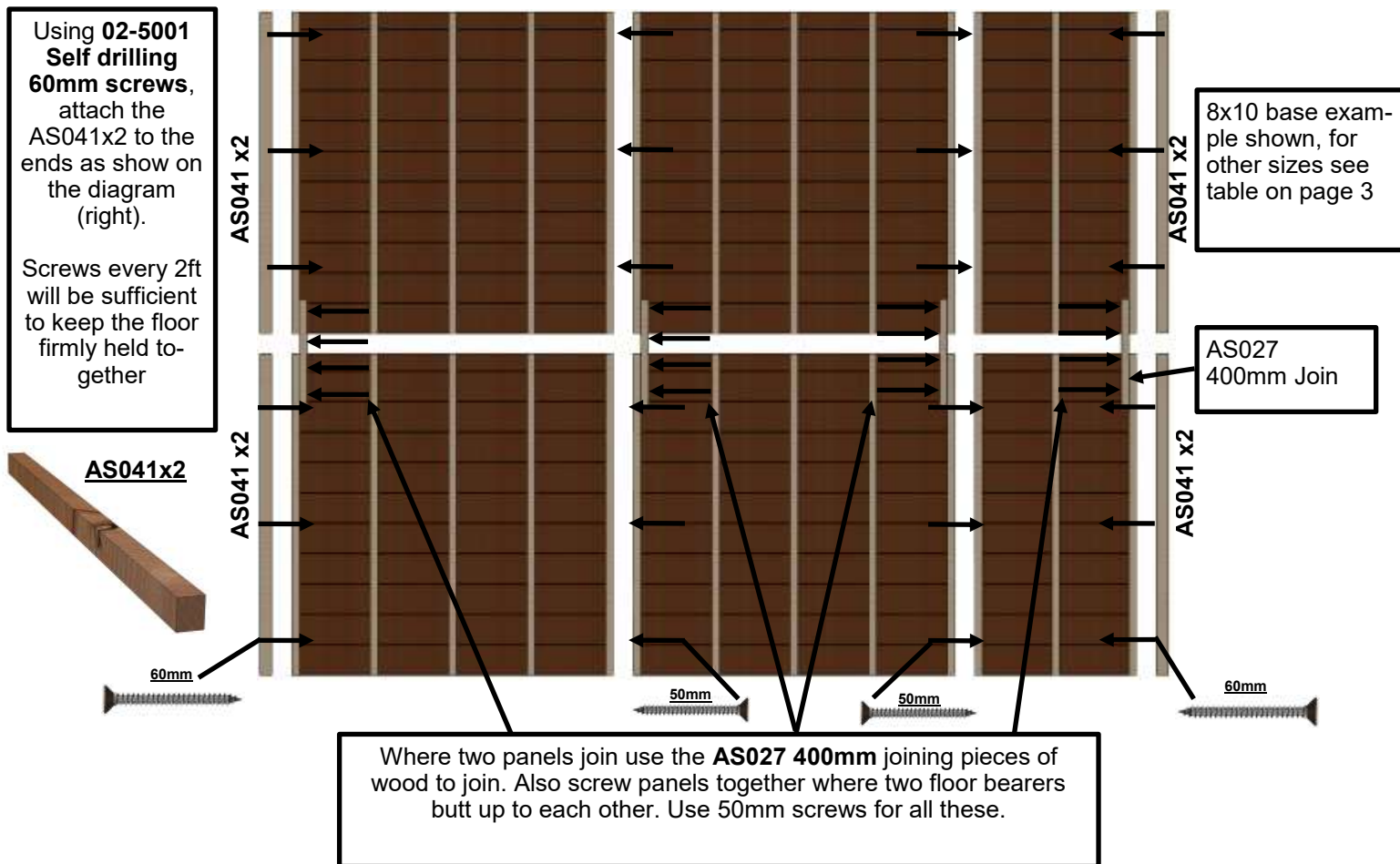

Laying the floor onto the base

Once you have assembled the floor you need to now lay this onto the base. Ensure the base is flat and level by using a spirit level. Then lay the assembled floor onto the base, once again checking that everything is flat and level.

A flat and level base is vital because if it is not level then you will experience problems such as the door not opening or closing properly, the roof not fitting properly and you may get gaps appearing. Use the spirit level across the width and length of the floor.

NOTE: Flipping the floor over and laying it onto the base should be done very carefully to avoid damage to the floor.

If you're building a floor that's 12ft or longer then you will have to screw the floors together when they're the right way or because it will be too big to flip. Use **50mm Screws and pilot drill** and screw from the top where the floors join and angle them so the screw goes through into both floors.

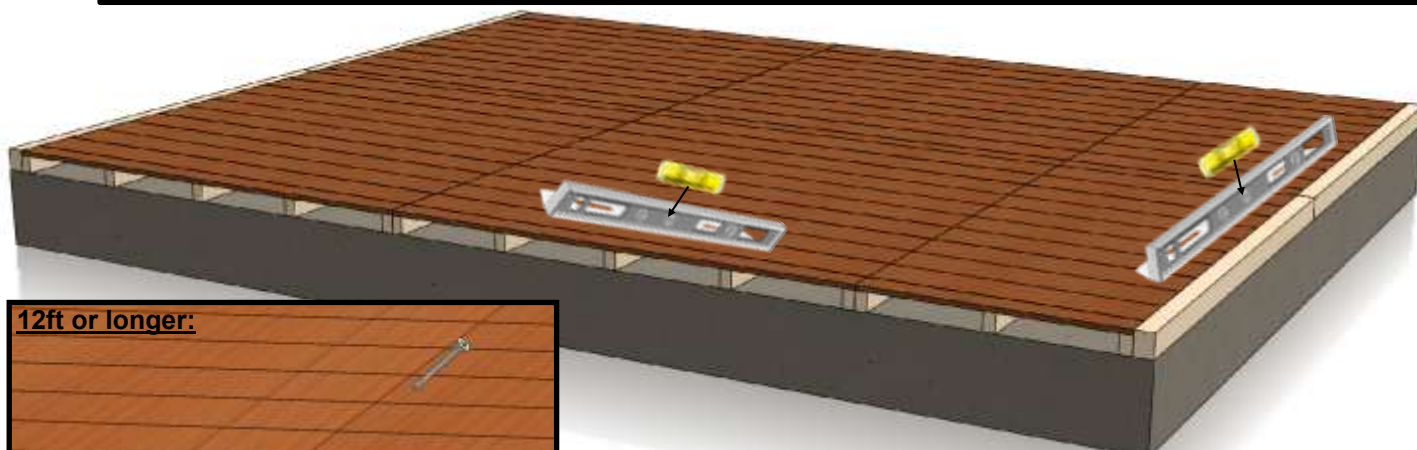

12ft or longer:

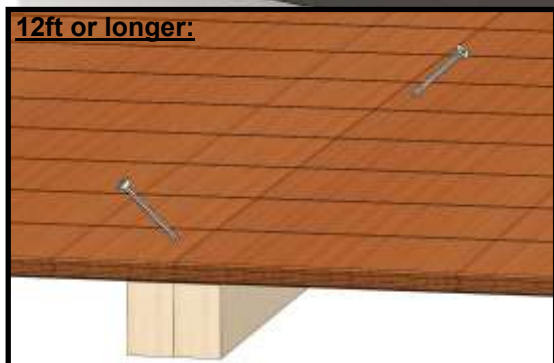

TIP:

Take time to make sure your original base + your wooden floor is level. The door will be affected if not level. If your concrete or slabs are uneven, you could consider ordering the optional Shedfast wooden base system

Sides Assembly

Removing the transit blocks

Before you start putting the sides onto the floor, you need to remove the transit blocks. They are nailed on to protect the overlapping cladding from snapping while in transit. Remove these blocks carefully using a hammer.

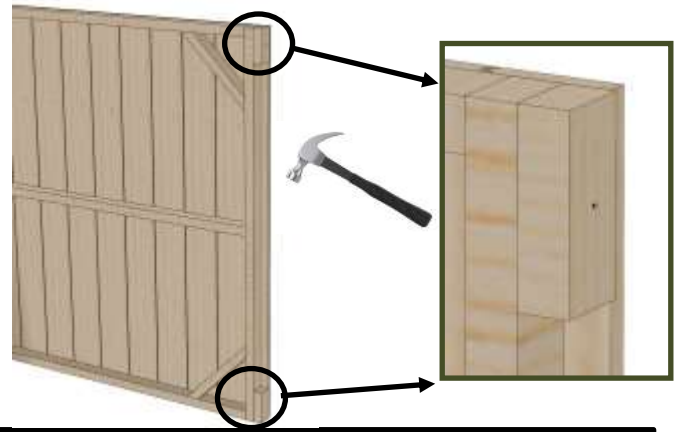

When attaching the sides together, use three **50mm wood screws** per vertical and ensure you make pilot holes with a 4mm drill bit.

NOTE: Because the plain, door and window panels are all the same size, you can position them wherever you want. There is no set order for them to be in, it's totally your preference.

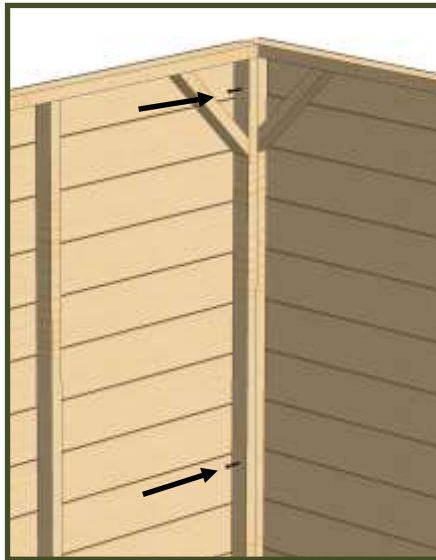

Pilot Hole size:

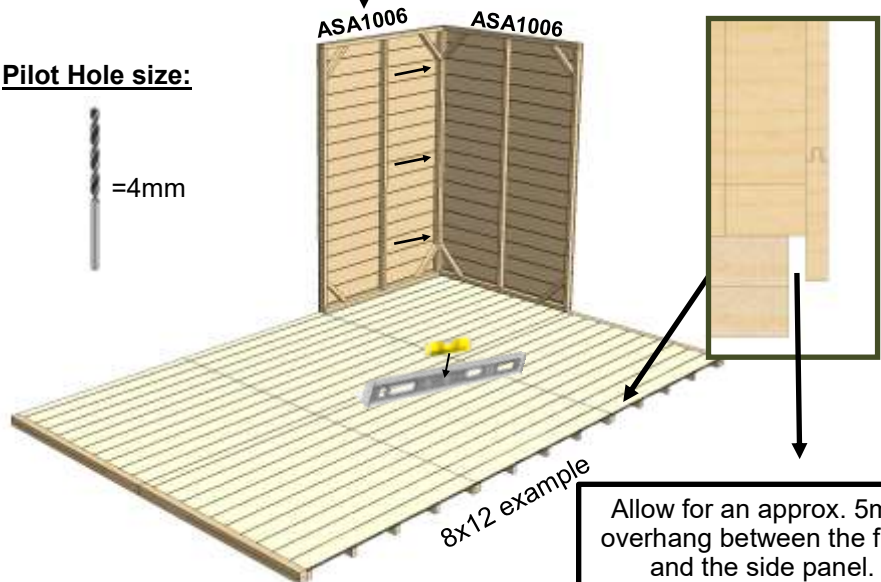

Allow for an approx. 5mm overhang between the floor and the side panel.

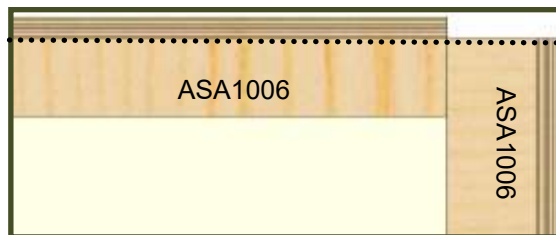
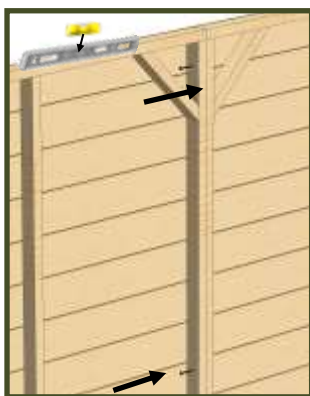

See how when the panels are lined up correctly, the cladding sits proud.



8x12 example

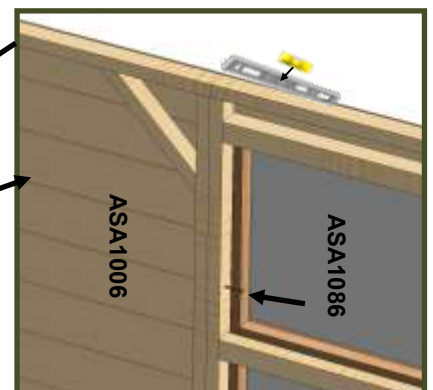

Installing the spacers

Once you have your sides on place on your floor, you can now go around the building and install the **ASA1103** and **ASA1104 Spacer Panels** to go above your side panels with **50mm screws**.

These extend the height of the side panels and allow the doors to pass the overhang at the eaves.

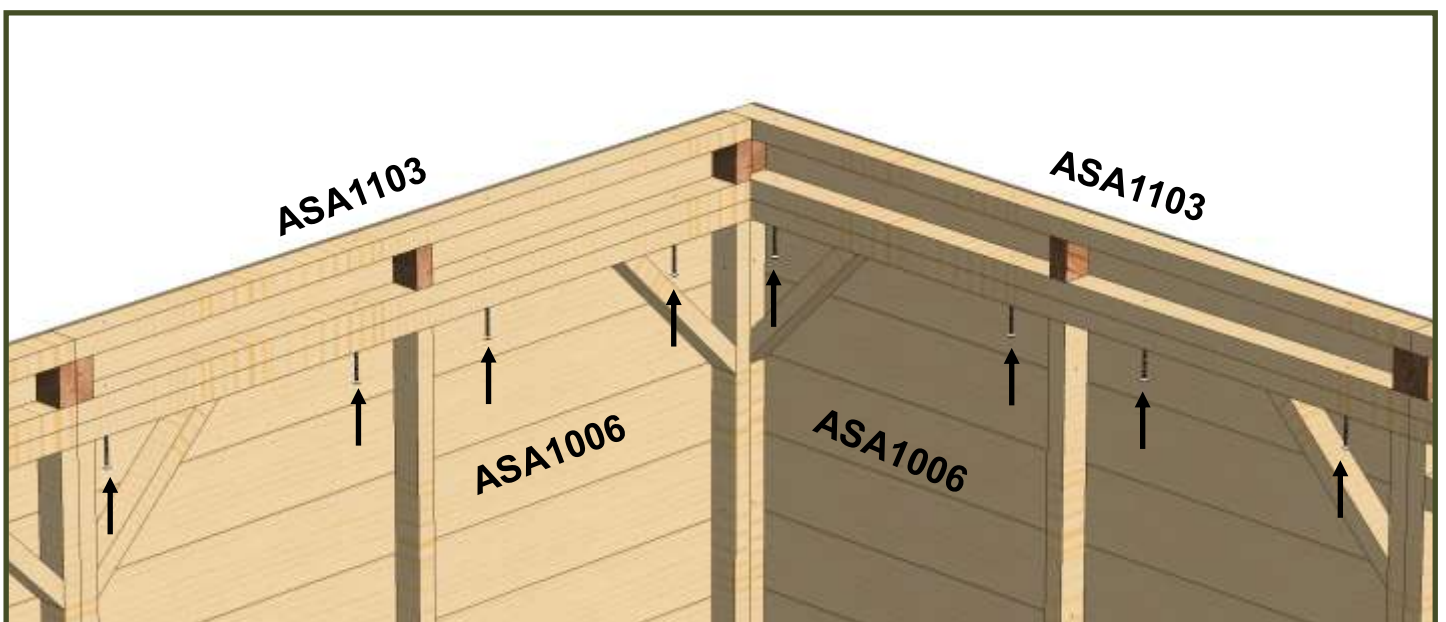
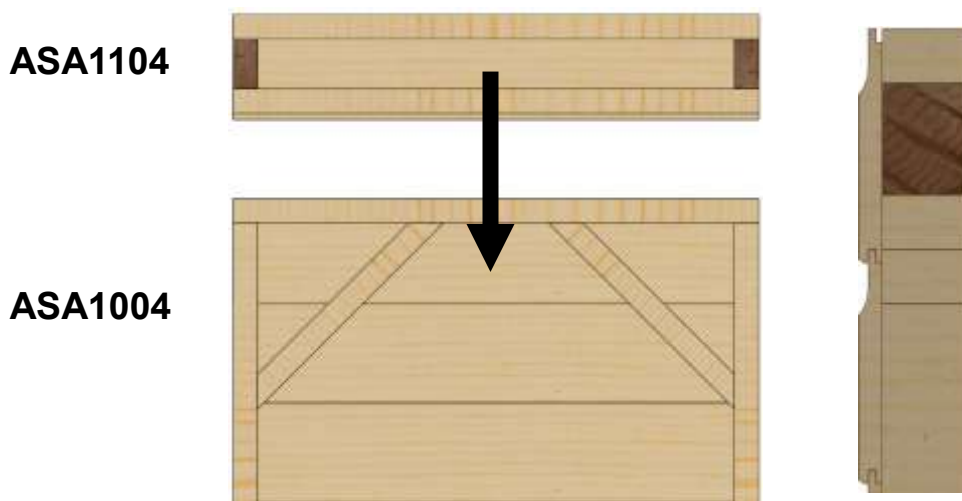
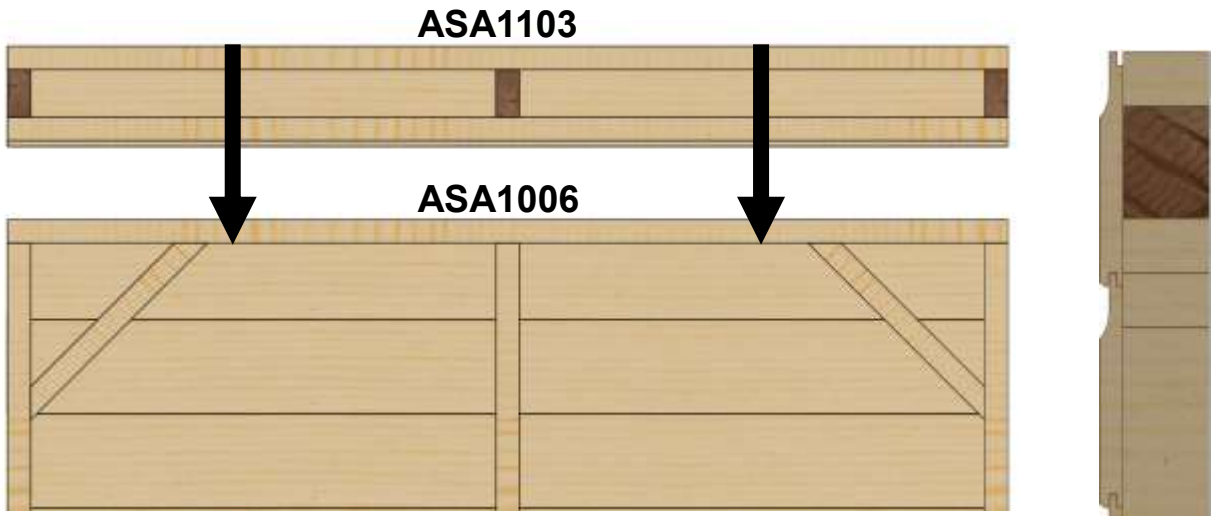

Assembling the apex pieces

You now need to assemble the apex pieces as they come in two parts, **ASA1029 8ft Apex Right** and **ASA1028 8ft Apex Left**.

Lay them out on the floor and **pilot drill 2 x 4mm holes** into the baton as seen below. Once you have made these pilot holes you can screw these together using **2 x 50mm screws**. Ensure the bottom of the apex panels are flush with each other before you attach them together so that when you put them onto the shed they sit correctly.

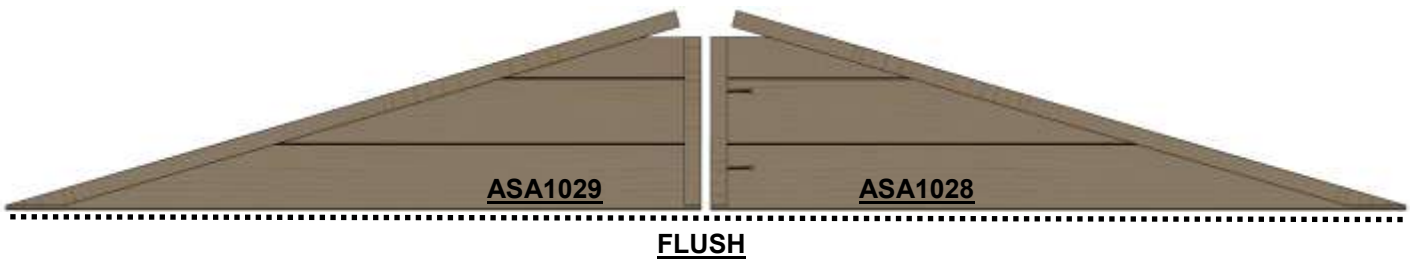
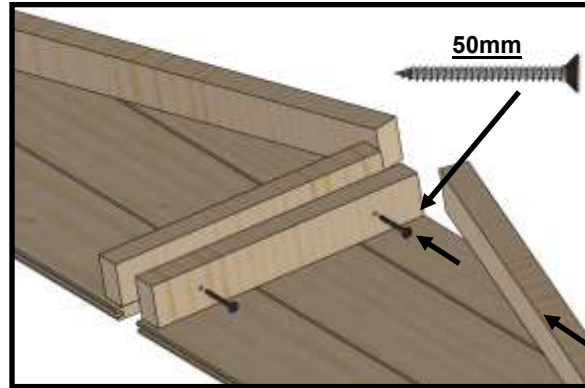

The apex panels **ASA1029 / ASA1028** can now be placed on top of the side panels at the gables.

Use **60mm screws** to screw the roof down and attach to the sides. See the arrows below for where to screw

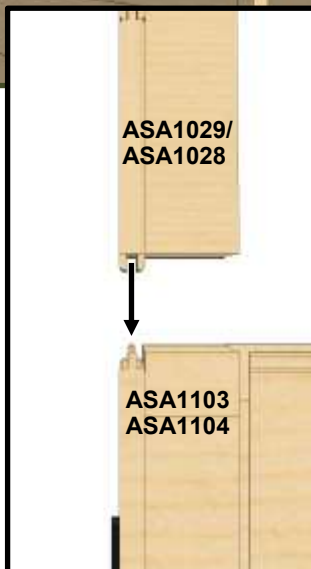
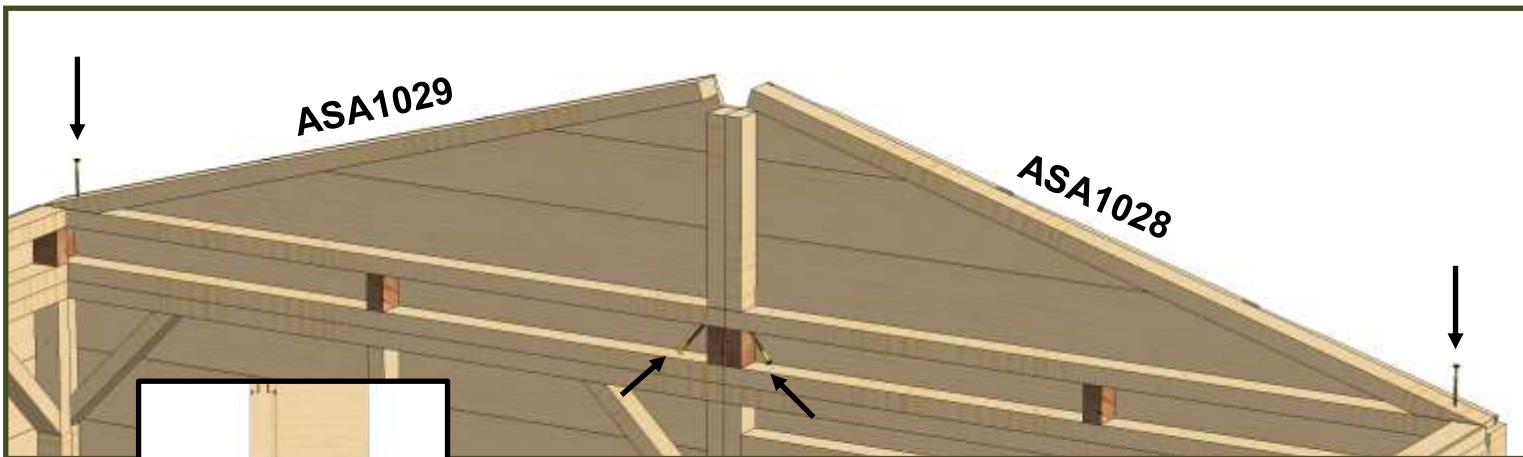

The cladding overhangs the Apex **ASA1028/29**, this means that when the **ASA1028/29** sits on top of the **ASA1103/ASA1104** the tongue can sit nicely in the groove.

Truss Assembly

Its now time to assemble the truss. It will arrive in sections that you need to put together with 80mm screws. You need to attach the separate AS039 batons to the pre assembled truss frame. See below for where to screw. Make sure that the AS039 baton is nice and flush with the corner at the top

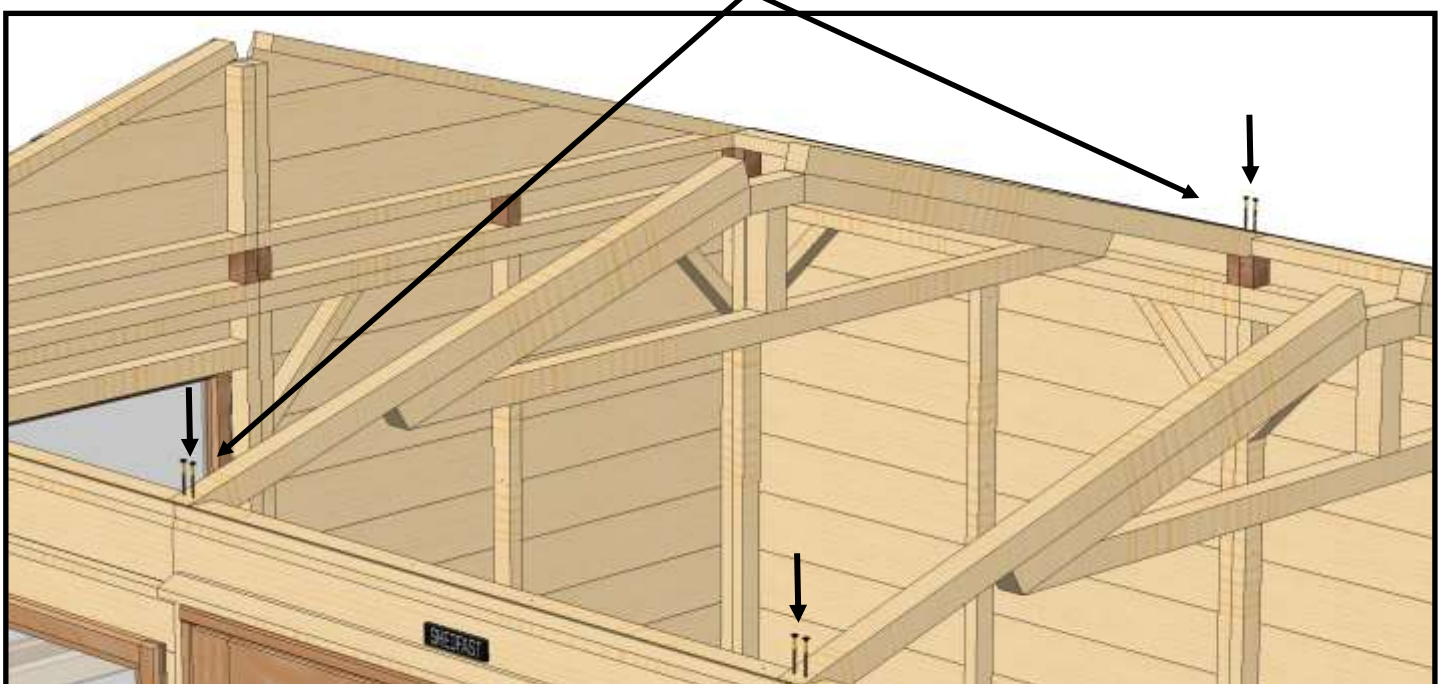
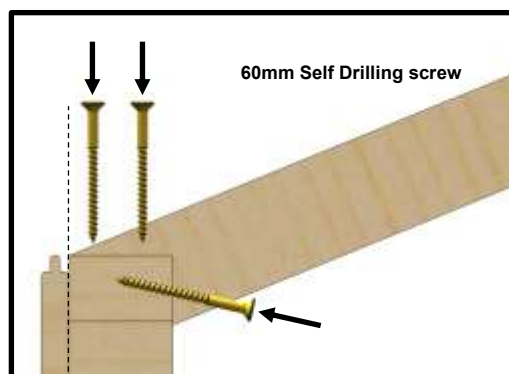
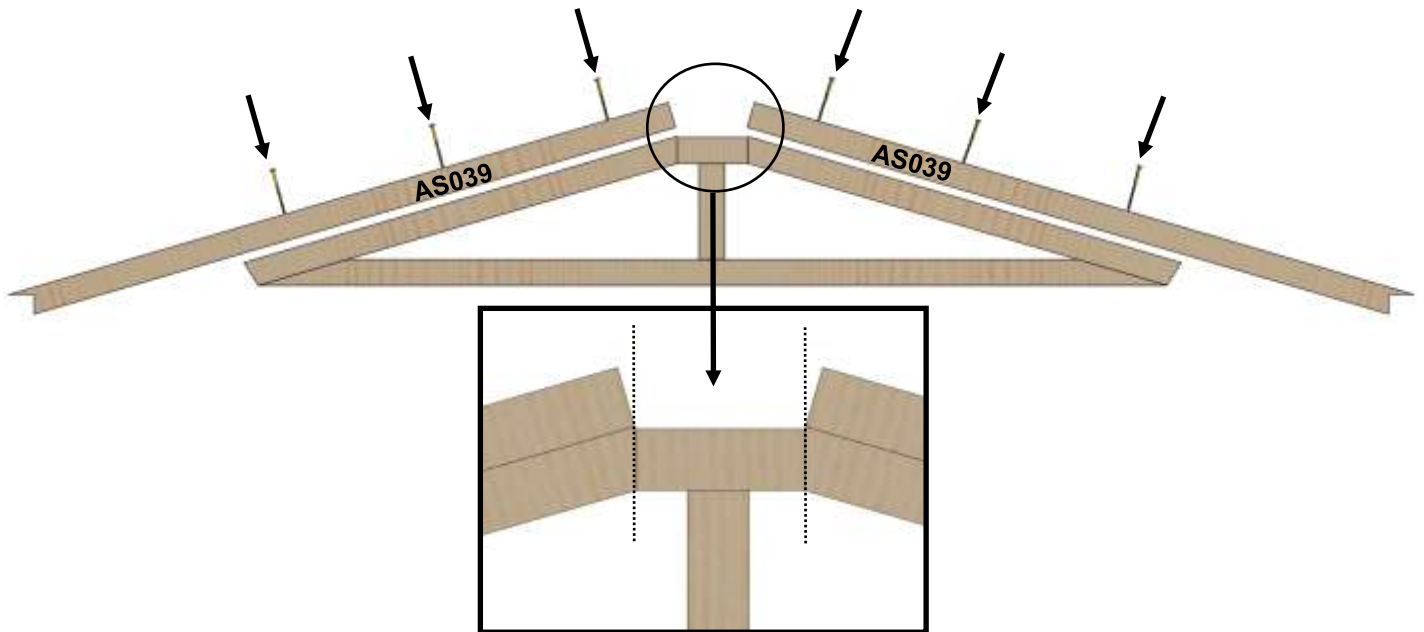

Trusses

Its very important to get the trusses spaced 22mm either side of the panel joins. This is because of the central baton of the roof panel. If the truss is in the correct place the roof panel will drop and fit nicely around the truss. Use 60mm self drilling screws to screw the trusses down.



8x6

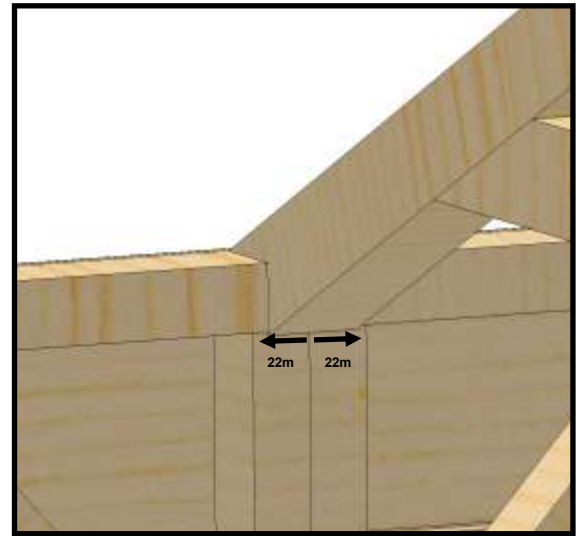

NOTE: On a 8x10 model, the trusses and roof panels must be as below, even if the ride panels are in a different orientation. It is not important that the side panel joint meets a truss but the joints in the roof must be over a truss.



8x8



8x10

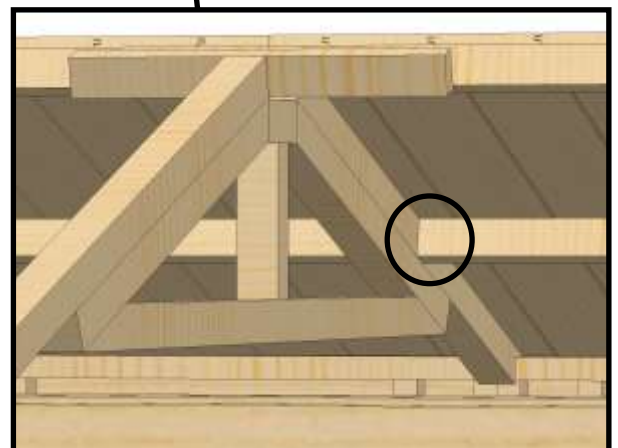



8x12



8x14

Roof Assembly

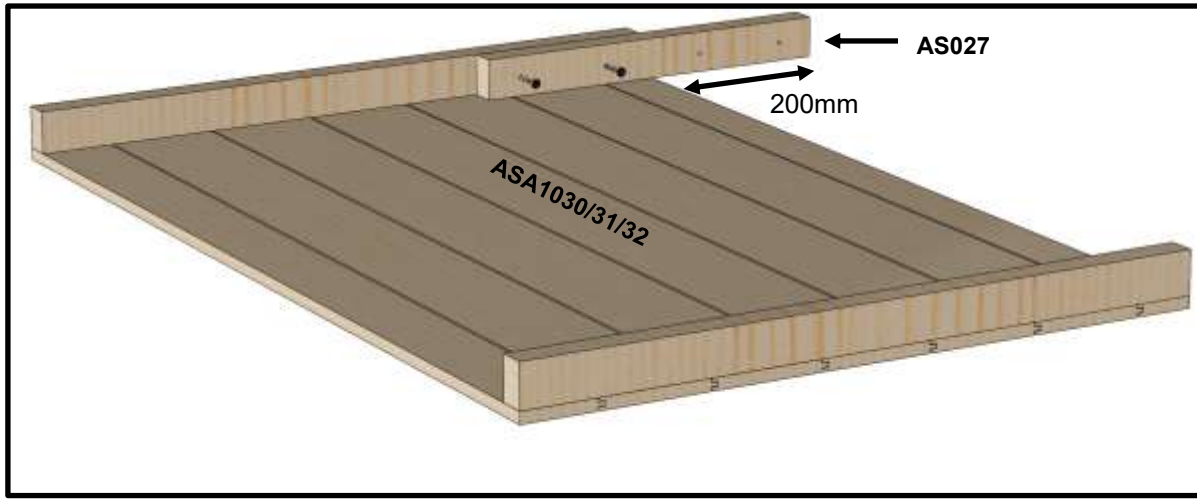

Attach the **AS027 Roof joiner** to the roof panels using 50mm screws. Remember to make 4mm pilot holes. Equally space the **AS027** so its overhanging 200mm from one side. You need to fix these on opposite ends of the roof sheet, one for the left slope and one for the right slope Once you have attached this you can hook the roof onto the **ASA1028/29** Gable end and the **ASA1035** Truss. If panels start with a tongue or groove, they are not meant to interact with each other, roof panels simply butt up to each other.

NOTE: Please do not stand directly or put your whole body weight on the roof.

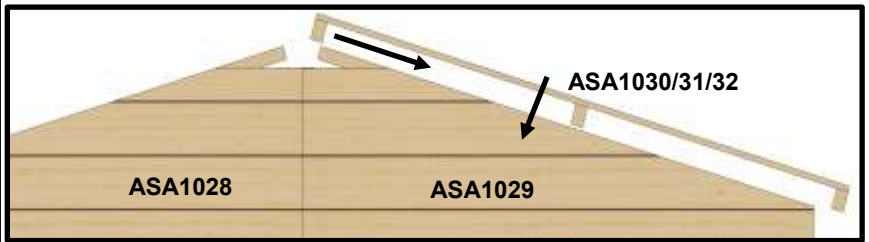

1. Screw on joining batons (50 mm screws and pilot drill)
2. Lift Panels onto roof
3. Even up overhand each end (44mm) and check its square.
4. Screw the joining baton to the other roof panel (50 mm screws and pilot drill)
5. Screw the ridge together using 60mm self drilling screws
6. Screw roof panels down using 35mm screws.

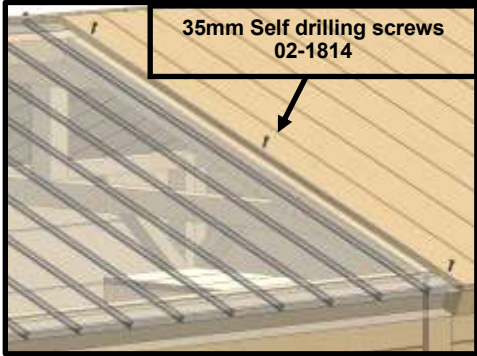

35mm Self drilling screws
02-1814

Carefully line up where you screw into the roof. You want to make sure you screw into the frame of the **ASA1035 Truss** and the frame of the **ASA1028/29 Gable tops**. The screws should be within 22mm from the middle of the roof and 44mm from the end of the roof

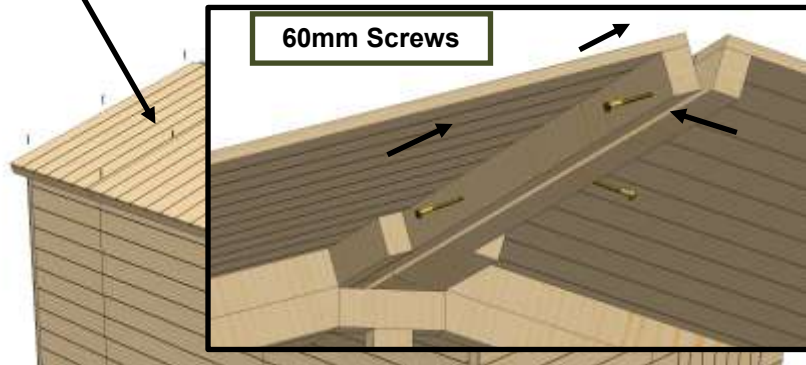

See the diagram to the right, this shows how the roof joint lines up with the side joint.

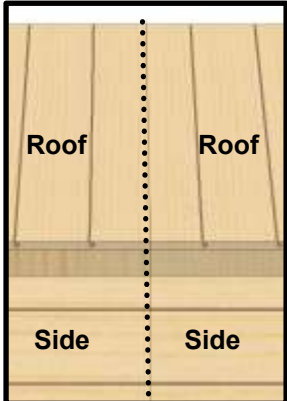

8x10 example

Felting

How to cut felt:

- Unroll out on the floor
- Mark correct length both sides of the roll using a tape measure.
- Use a straight edge as a ruler and cut with a Stanley knife
- Be cautious when cutting as if you cut one piece too big then the left overs will be too small.

Lengths to cut to	Felt 1m Wide	
	8x6	2107mm x3
	8x8	2707mm x3
	8x10	3307mm x3
	8x12	3907mm x3
	8x14	4507mm x3
	8x16	5107mm x 3
	8x18	5692mm x 3

NOTE:

If you have a partition, add 56mm to the length of the felt you are cutting



Felt Clout
02-1675

Once you have your felt cut to the correct length its best to roll it back up and place the roll onto the roof and then roll it back across the roof. Once its rolled out, space it out evenly so that it overhangs 50mm evenly over each gable end and around 2mm at the eaves of the roof. Now its in the correct position, place a Felt clout at each top edge to stop it from sliding. Pull it down so its nice and flat and begin to tac at the eaves.



Felt clout paced at the top (each side) to stop it from sliding down. Be careful to not place the tac too close to the edge or you could run the risk of damaging the cladding when hammering down the tac. You only need two or three felt clouts along the top as the next piece will overlap and be fully nailed down.

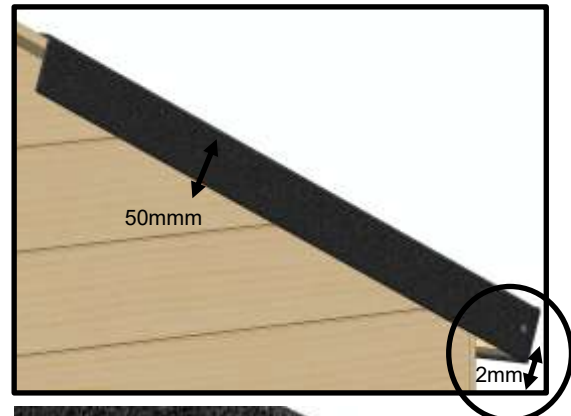

The felt should overhang slightly by about 2mm. It should not be tucked under or nailed 'up'. Also overhand the end by 50mm

Repeat this step for the other side of the roof before you put the top piece on.



Tack the felt to the eaves, space the clouts approximately every 100mm. Ensure the felt overlaps the bottom roof baton by about 2mm to allow water to drip away from the

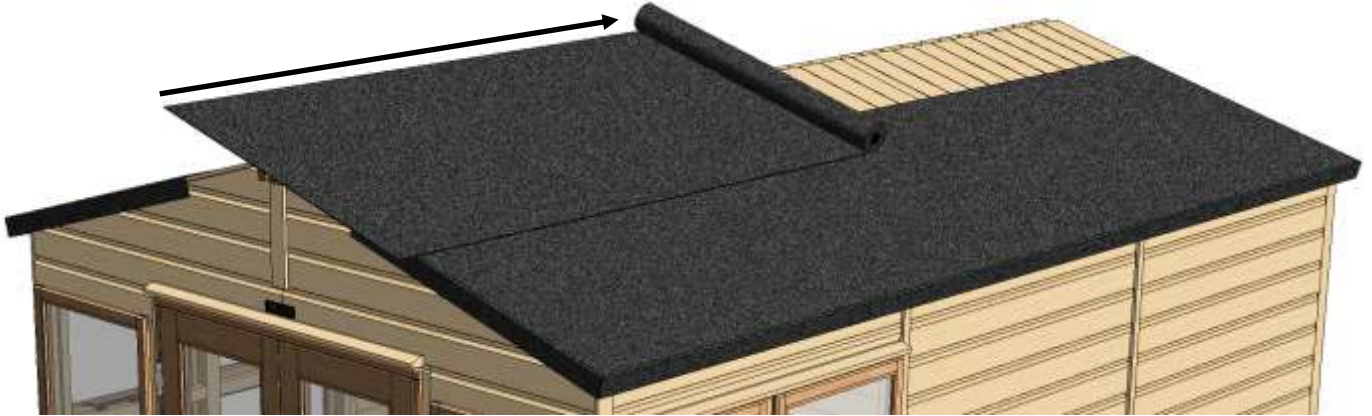

Cut your 1m felt to the correct length and roll that out across the top. Evenly space it over each side and get your 50mm overhang at the front and back as you have done previously. Place a felt clout every 100mm or so.

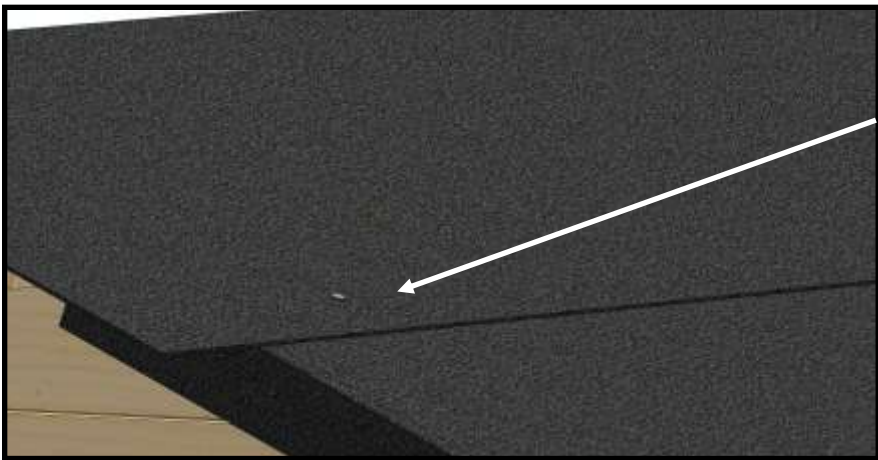

Put a clout in to stop the roof felt from sliding. Pull the felt tight on the other side before you put the clout in. This makes sure it is nice and flat to the roof. Do this on each side before putting all of the clouts in. Again, be careful not to place the clout too close to the edge or you could run the risk of damaging the cladding when hammering down the clout.

The sheets of felt should overlap by a minimum of 100mm. This is to ensure no water can blow through the gap and get to the wood below.

Like you did with the piece of felt below, tack down with clouts approximately every 100mm .

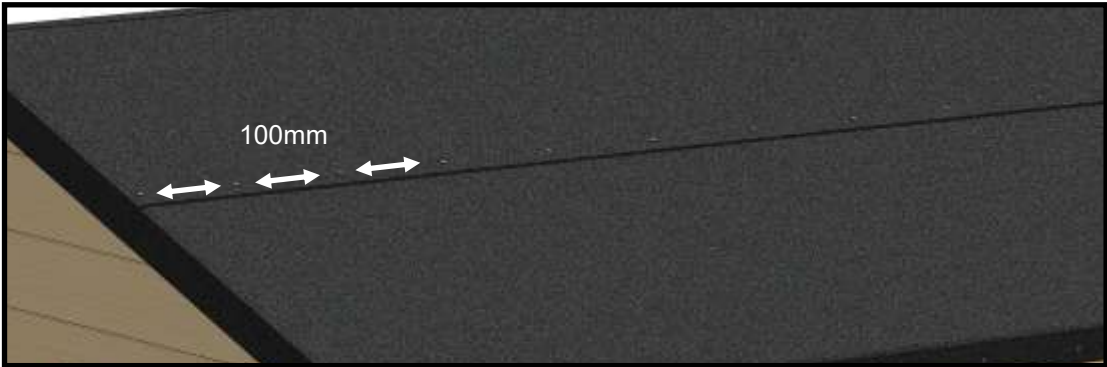

NOTE:
Please do not stand directly or put your whole body weight on the roof.

Facias and Capping

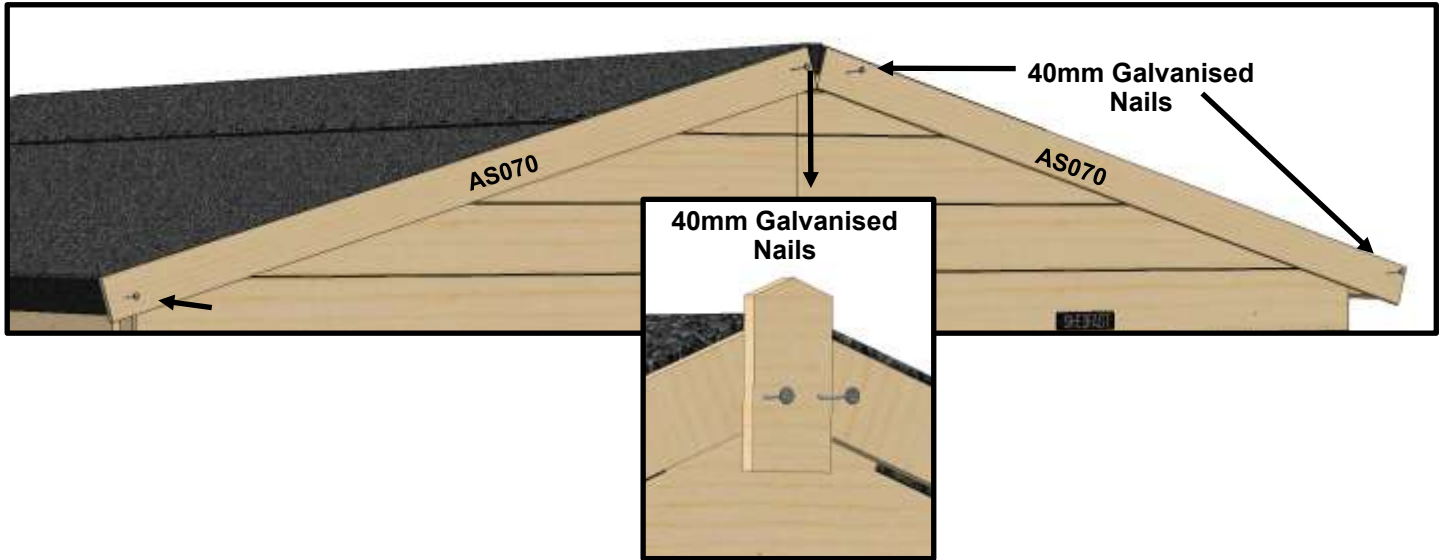

Now go round the building attaching the capping using **40mm galvanised nails**. The **12x28** capping piece are to go inbetween window/door panels on the front and sides. The **12x56** capping is to go on the ends of the front and also all across the back.



Weather Strips for above opening windows and doors

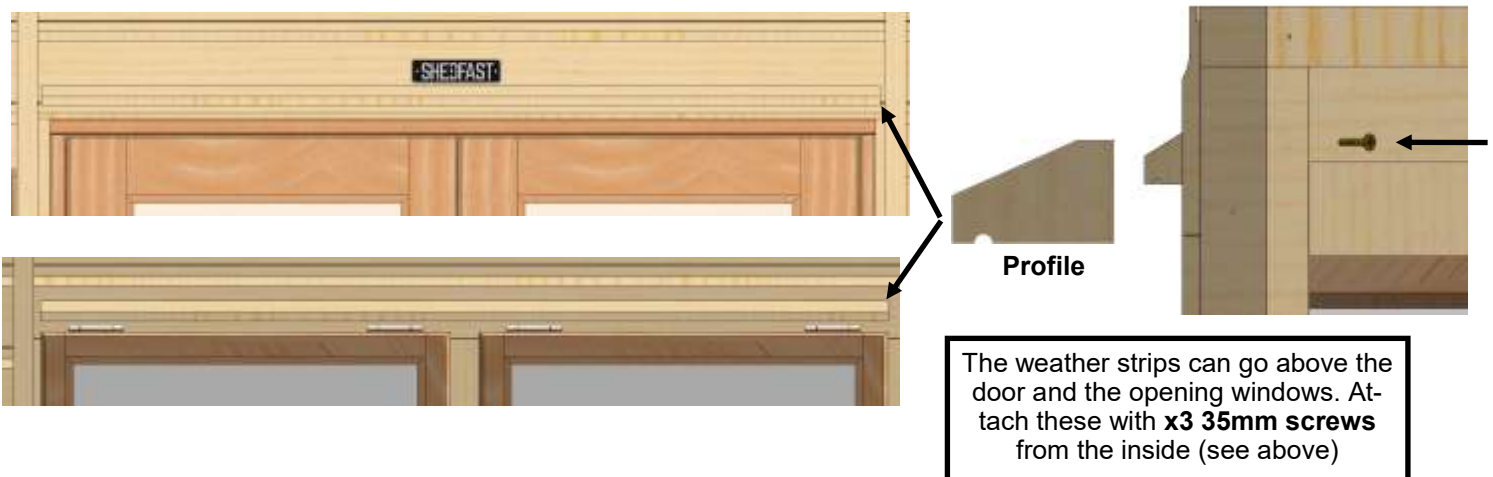

Fixing the sides to the floor

Now you have the roof fixed in position its now time to secure the sides to the floor. We do this last so that it is easier to square the roof up

Make sure the sides are equally spaced out from the floor (approx. 5mm from each side) and then put in your **60mm Screw 02-5001**

Place a screw down approximately every 2ft along the front, back and sides.

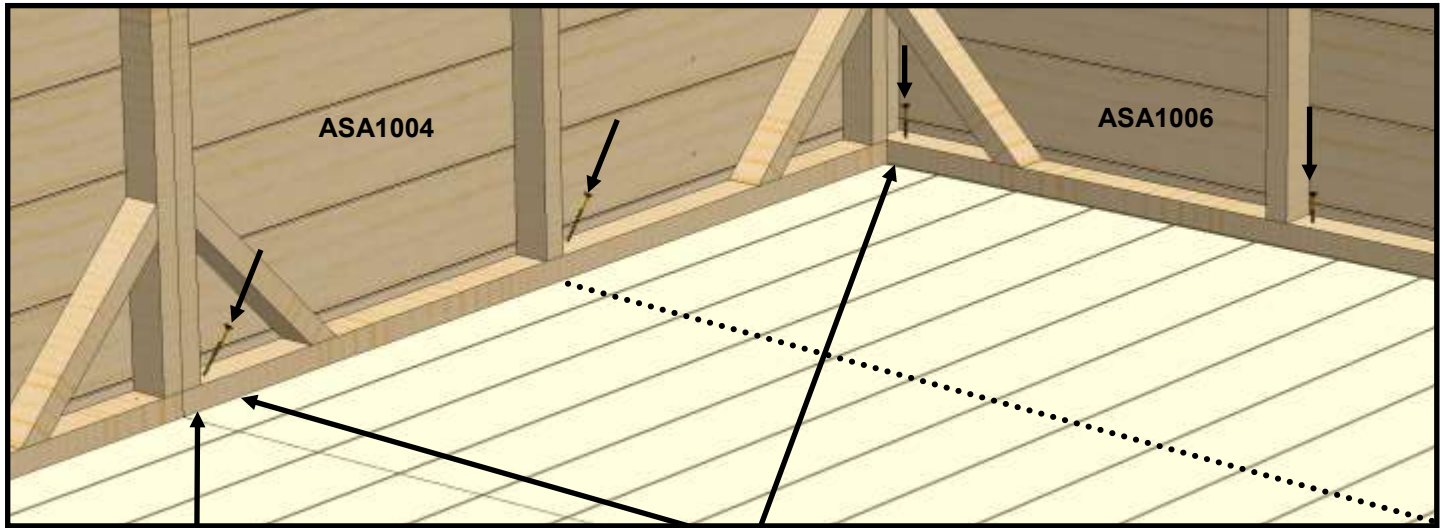





You will only need one screw at each joint







Some screws may need to be angled to catch the floor joists below.













You can use the nails on the floor boards to see where the baton is underneath. Line your screws up with these nails when fixing the sides down to the floor





Standard Product Tables

	ASA1004 2ft Panel 600x1856	ASA1086 Opening Window Panel 1200x1856	ASA1006 4ft Panel 1200x1856	AS1087 Full Window Panel 1200x1856	ASA1088 Double Door Panel 1200x1856
					
8x6	2	2	2	0	1
8x8	0		4	0	
8x10	2		4	0	
8x12	0		6	0	
8x14	2		6	0	
8x16	0		8	0	

	ASA1030 8x4 Roof 1300x1300	ASA1032 8x4 Infill 1200x1300	ASA1031 8x2 Roof 695x1300	ASA1029 8ft Apex Right 341x1200	ASA1028 8ft Apex Left 341x1200	ASA1035 Truss	AS039 Truss Bar 44X44 1173mm
							
8x6	2	0	2	2	2	1	2
8x8	4	0	0			1	2
8x10	2	2	2			2	4
8x12	4	2	0			2	4
8x14	2	4	2			2	4
8x16	4	4	0			3	6

	ASA1023 4x4 Floor 1195x1195	ASA1026 4x2 Floor 600x1195	ASA1095 2ft Window Panel 600x1856	ASA1103 4ft Spacer Panel 1200x120	ASA1104 2ft Spacer Panel 600x120
					
8x6	2	2	2	6	2
8x8	4	0		7	2
8x10	4	2		8	2
8x12	6	0		10	0
8x14	6	2		10	2
8x16	8	0		11	2

	AS070 Fa- cia 12x56 1317mm	AS101 Trim 12x56 295mm	AS305 Finial	AS041X2 Floor Extend- ers 44x56 1195mm	AS027 Roof Joiners 44x28 400mm
					
8x6	4	2	2	4	6
8x8					6
8x10					6
8x12					8
8x14					8
8x16					11

	AS171 Trim 12x28 2124mm	AS172 Trim 12x56 2120mm	AS189 Weather Strip 1162mm	AS306 Shedfast Name Badge
				
8x6	3	5	3	1
8x8	4	5		
8x10	4	6		
8x12	4	6		
8x14	5	7		
8x16	6	7		

<u>Felt Length</u>	<u>4.1m</u>	<u>5.4m</u>	<u>6.6m</u>
<u>Felt Width</u>	<u>1m Wide</u>	<u>1m Wide</u>	<u>1m Wide</u>
8x6	0	0	1
8x8	2	0	0
8x10	1	0	1
8x12	0	1	1
8x14	1	2	0
8x16	0	3	0

8ft WIDE APEX SUMMER- HOUSE



Unpacking Pallet

The first thing you need to do is carefully unpack the pallet. Each panel is screwed to the diagonals at the top and bottom. Remove each panel, one at a time, by unscrewing the screws at the top and bottom. Take the panel off the pallet and place it somewhere safe.

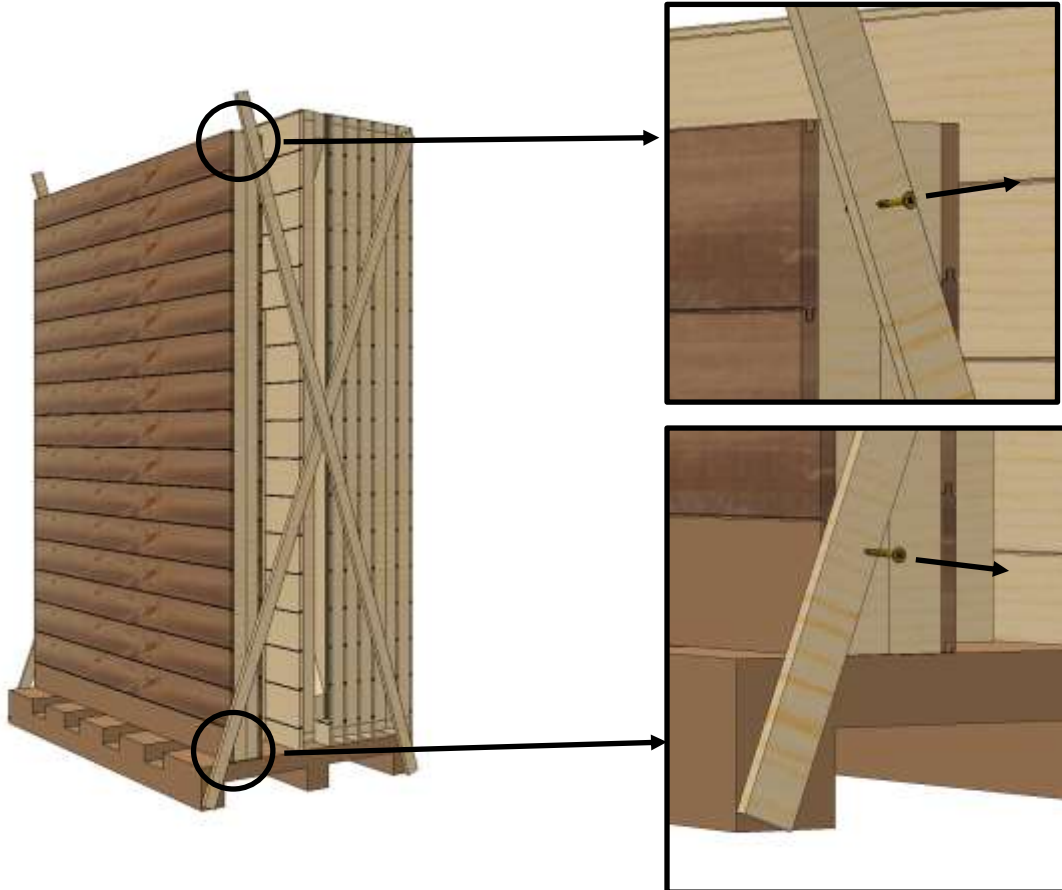

SHEDEFAST

www.greenhousepeople.co.uk

Call us on 01782 385400

The Greenhouse People Ltd, Unit 19 Blythe Park, Cresswell, Stoke-on-Trent, Staffordshire, ST11 9RD